

PCM SERIES

EMERGENCY POWER CONTROL MODULE



ACCESSORIES

Specifier's Reference	
Project Name	Type
Catalog No.	
Comments	

Turns locally switched fixture into an emergency light!

- **Listings/Certifications:** UL/CUL. UL924, UL 94V-O Flame Rated. Meets or exceeds NEC, NFPA and OSHA Life Safety Codes

Specifications

- **Faceplate:** Light weight flame resistant composite material with LED readiness indicators, test switch and speakers for audible emergency power circuit failure alarm.
- **Recessed Power Module:** Shallow module recesses only 1.5" into wall or ceiling and fits in standard single-gang electrical box. 120V or 277V operation. 20amp load capability. 1,000 W Tungsten Lamp Load, 1 HP with 120V unit. 1,800 W Tungsten Lamp Load, 1.5 HP with 277V unit. Surge and short circuit protection. 20 to 150° F operating temperature.
- **Emergency Operation:** Units designated as emergency will illuminate when emergency power is initiated whether local switch is on or off.
- **Normal Operation:** Both utility (green) and emergency (red) LED indicators on. Local switch operates all circuit lighting fixtures as required. When local switch is turned off, units wired as emergency lights operate an additional five seconds to test emergency system readiness. An audible alarm will sound if emergency power is lost during normal operation.
- **Testing:** Automatically tests for five seconds each time local switch is turned off. Manual testing available through switch on faceplate lights emergency fixtures for five seconds regardless of local switch position.
- **Installation:** Approved for wall or ceiling mount applications. Quickly and easily installs in standard single-gang j-box. Use 1/2" single-gang plaster ring and 3" deep electrical box.

Ordering Information

Series		Voltage	
PCM	-	120V	120V Emergency Power Control Module
PCM	-	277V	277V Emergency Power Control Module

Dimensions & Mounting

**PCM - CEILING OR WALL
INSTALLATION**

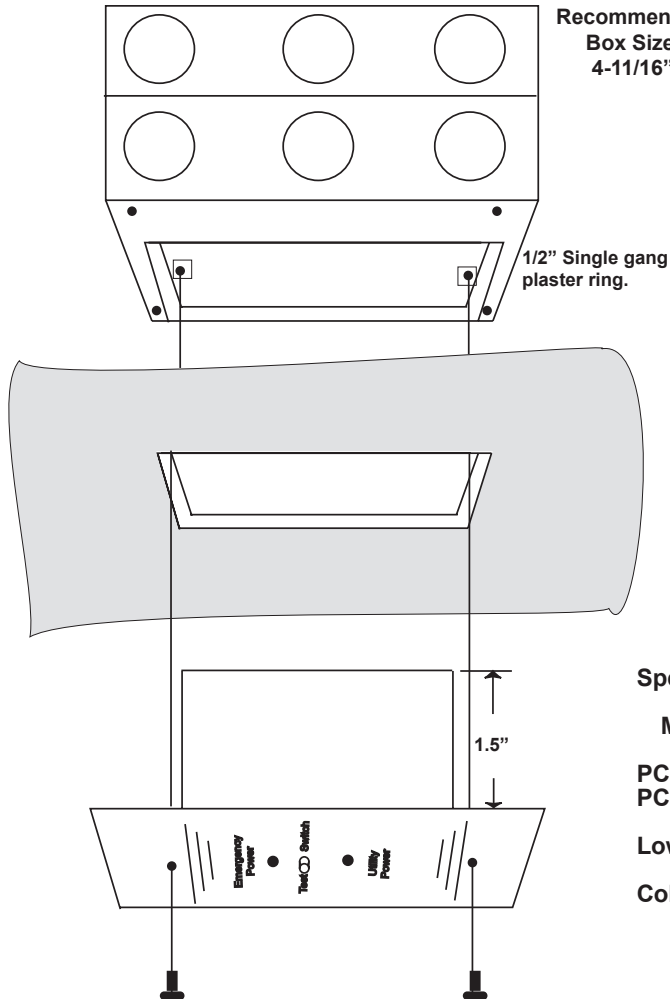

Recommended
Box Size
4-11/16"

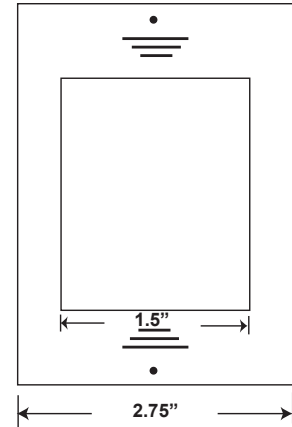
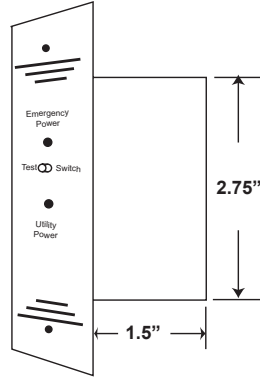

Specifications

Model	Ballast Load	Lamp Load	Amp Rating	HP Rating
PCM-120V	20 amp	1,000 watts	20	1.0
PCM-277V	20 amp	,500 watts	20	.5

Low profile design for installation in standard electrical boxes

Color: White

Weight 8 oz

Wiring Diagram

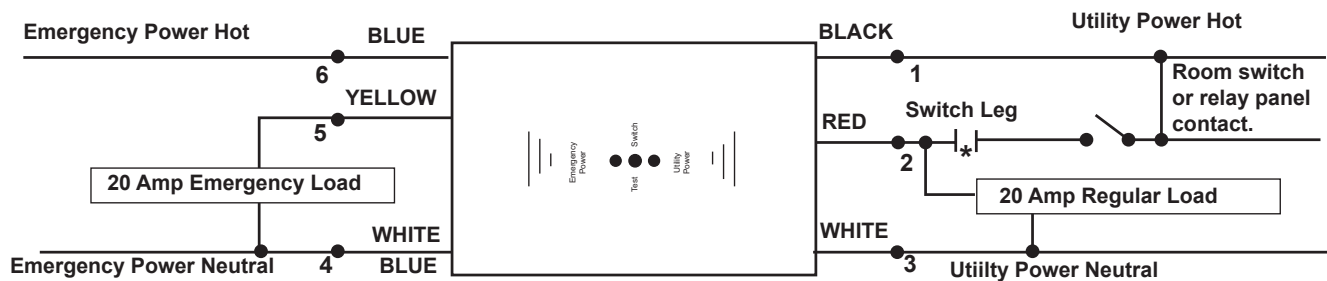

It is recommended to number field wiring exactly the same with numbers provided.

*Optional occupancy sensor contact. N.O. contact closes.